

Understanding and Using Sealless Rotary Pumps

There are many sealless centrifugal pump designs that have been well established for many years. When handling viscous liquids, shear sensitive liquids or flow/pressure requirements outside of centrifugal pump ranges, rotary, positive displacement pumps provide reliable, efficient, economic solutions. Sealless rotary pumps are available in an everwidening range of configurations. The need for sealless pumps ranges from cosmetic housekeeping issues and maintenance costs to the pumping of toxic, corrosive, crystallizing or other dangerous or difficult to seal liquids. Sealless refers to the absence of a dynamic seal where the pump shaft penetrates the pump casing. Dynamic seals such as lip seals, mechanical seals, packing rings and similar arrangements, are prone to wear and leakage. Static seals such as o-rings or gaskets generally provide very long term, high reliability sealing due to the absence of relative motion. Excessive mechanical seal leakage or failure represent over 50% of pump repair incidents.

Conventional Shaft Sealing

Shaft packing rings are designed as controlled leakage devices and must be permitted to leak in the order of 10 to 20 drops per minute to stay lubricated and to minimize shaft or sleeve wear and damage. Lip seals will frequently “weep” liquid and generally have a life expectancy of a few thousand hours under good seal conditions.

Mechanical seals, figure 1, are in extensive use on industrial pumps and can provide good life. They, too, however, are controlled leakage devices. The sealing faces cannot be permitted to contact in a dry environment. Some liquid must pass between

the rotating and stationary face in order to minimize friction and to carry away the heat generated. If this leakage evaporates when reaching the atmosphere, then there is no visible leakage. If it doesn't, leakage in the order of 10 drops per hour might be the best achievable. Figure 2 illustrates the mechanical seal dilemma. Some seal manufacturers rely on high face loading to minimize leakage but at the expense of seal longevity. Others do the opposite, which provides longer life but greater leakage.

Figure 2: Mechanical seal leakage vs. life

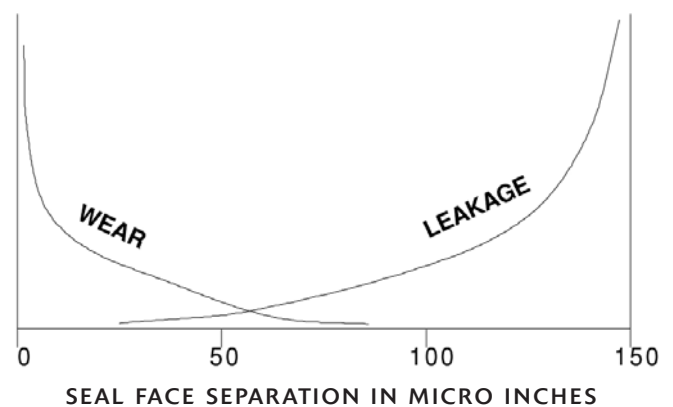

Tandem and double seals as well as gas-purged seals have been used in difficult or dangerous sealing services. These arrangements can be very elaborate and expensive. High skill and high cost maintenance is a requirement that goes along with using pumps with these shaft sealing arrangements.

Figure 1: Conventional mechanical seal

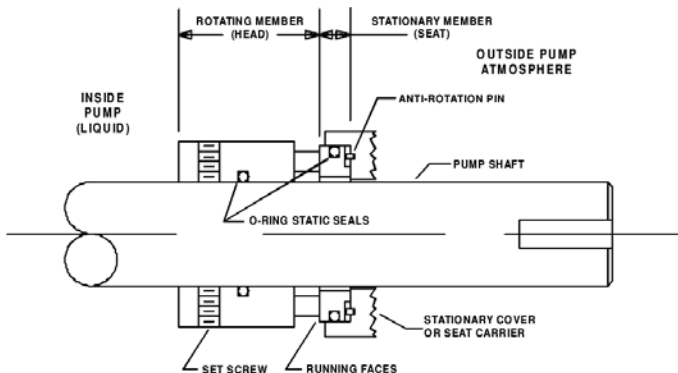

Figure 3: Submersible hydraulic elevator pump and motor



Unsealed Pumps

Unsealed pumps are those with no shaft seal that are permitted to leak in an environment that does not cause the leakage to be a problem. Figure 3 is an example of such an arrangement. Shown is a three-screw oil hydraulic elevator pump/motor package. The pump shaft plugs into the motor shaft. The pump shaft end bearing also acts as the motor shaft end bearing. This entire package is bolted to the bottom of an oil reservoir. The motor is of open construction and operates submerged in hydraulic oil as does the pump. Leakage from the pump shaft end merely returns to the reservoir. There are, perhaps, half a million such units in operation worldwide. They handle pressures to 1000 PSI (70 BAR) and power levels up to 100 HP (75 KW).

Figure 4: Unsealed tank mount main and emergency lube pumps

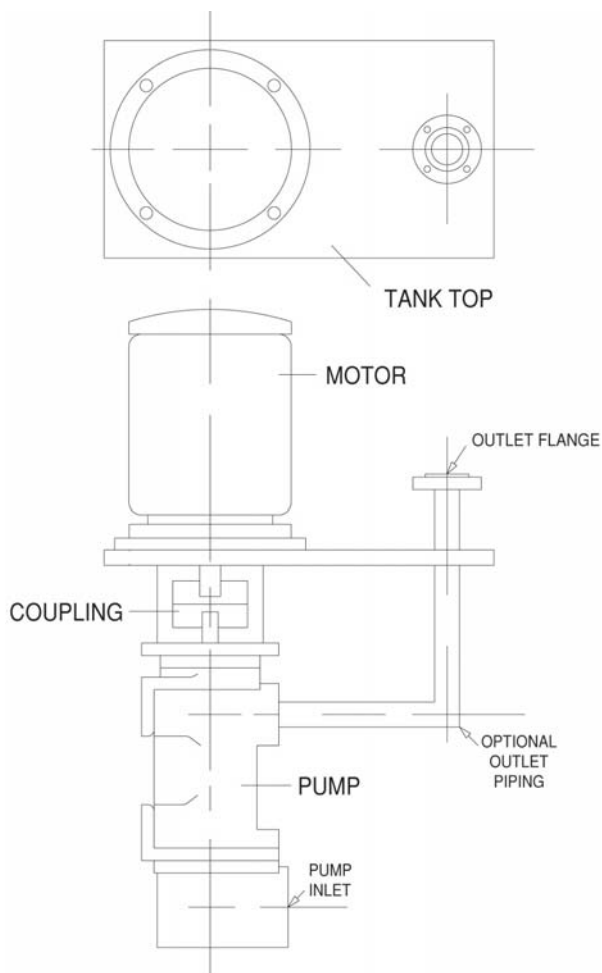
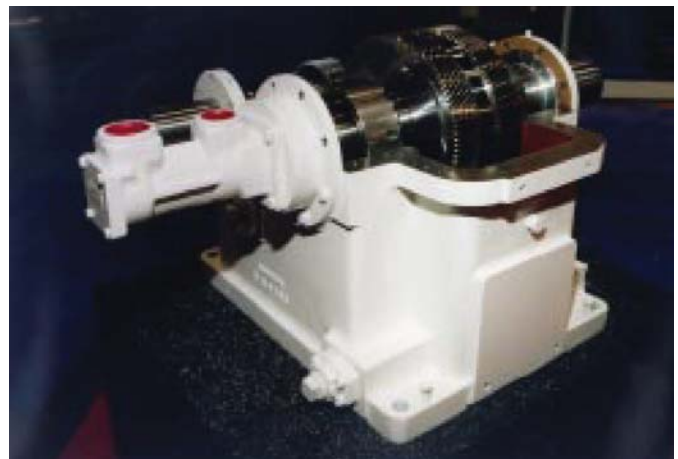

Figure 4 shows main and emergency lube oil pumps and drive motors mounted to a tank top fabrication with relief valves and discharge piping. When installed on a lubricating oil reservoir, the pumps will be vertically submerged with the electric motors outside the tank. The flexible couplings between motors and pumps are below the tank top. Again, leakage at the pump shaft is allowed to drain back into the reservoir. Figure 5 shows a lube oil pump mounted to an otherwise unused shaft of a 600 HP (450 KW) speed reducer. The pump is driven by the gear box shaft. Leakage from the pump goes through the gear box bearing drains to the bottom of the gear case which acts as the oil reservoir.

Figure 5: Unsealed lube pump driven by lubricated machine



Sealless Pumps

Completely sealed rotary pumps are available from a number of manufacturers. Styles include magnetic drive pumps and canned motor/pumps as well as the peristaltic (hose or flexible tube) pump.

Figure 6: Peristaltic (hose or flexible tube) pump

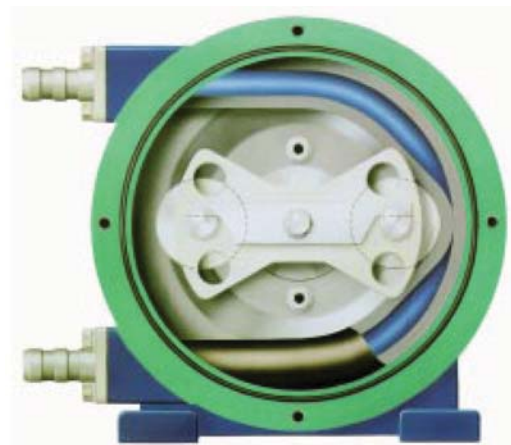

The peristaltic pump, figure 6, is available from dosing size flows, fractions of a milliliter per minute, to about 150 GPM (34 m³/h) or more at pressures as high as 220 PSI (15 BAR). They operate at relatively low speed, 20 to 200 RPM, and are used for metering, pumping liquids with some abrasives and handling easily damaged sensitive liquid products. Rollers compress the hose driving the liquid ahead of the compression point. Metering accuracy is very good. Chemical compatibility is entirely a hose issue. A good variety of hose materials can be used with peristaltic pumps. Hose life depends on material and operating conditions but can range from a few hundred to several thousand hours. Unless the hose fails, peristaltic pumps are completely leak free. Some units are available designed such that a hose leak inside the pump is still contained while an alarm or shutdown is initiated.

Figure 7: Magnetic drive operation (Courtesy Micropump, Inc.)

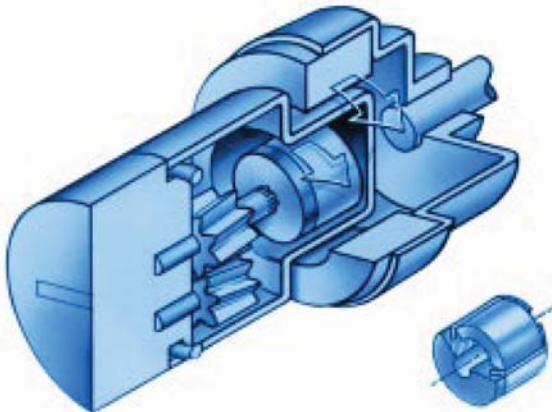

Operation – Magnetic Drives

While existing since the 1970s, magnetic drive rotary pumps came into prominent use in the 1990s. All the magnetic couplings operate on the same principles, figure 7, although design details will differ among pump manufacturers. The pump shaft has a cylindrical hub mounted to it. The outside diameter of the hub contains high strength magnets with the entire hub either potted or canned to protect the magnets from the liquid being pumped. Around the pump hub, a can or containment shell is installed. This can seals the pump from external leakage. The can must be a non-magnetic material, frequently stainless steel, Hastelloy or a non-metallic material. The non-metallic can eliminates nearly all eddy current losses. The metallic cans will incur some temperature rise and minor power losses. Outside of the can, a driven cylindrical hub surrounds the can. Its inside diameter is lined with high strength magnets as well. As this hub is rotated, its magnetic

fields cut through the can and engages the inner driven hub magnetic fields. Thus, the pump shaft rotates without physical connection to the drive and therefore no dynamic shaft seal is needed. Cans tend to be thin walled to minimize the distance between the inner and outer magnets. Since magnetic field strength decays with the square of distance from it, the closer together the magnets operate, the more cost effective the coupling will be. Can-to-hub clearances will vary with manufacturer but are in the order of 0.060 to 0.150 inches (1.3 to 3.8 mm) radially. Can wall thickness is typically in the order of 0.100 to 0.150 inches (2.5 to 3.8 mm). Some coupling designs incorporate a rub ring on the outer drive hub. It will contact the coupling frame before the hub can contact the containment can. This feature provides additional protection to the can in the event there is a problem with the drive hub/ shaft bearing system.

Magnet materials are usually Neodymium or Samarium Cobalt. The Neodymium material is less costly per unit of torque transmission capability (stronger per unit volume) but limited to about 225°F (107°C). The Samarium Cobalt material, while more expensive, is usable for liquid temperatures to 400°F (204°C) or more. Both materials lose strength with increasing temperature and both will suffer irreversible strength loss if operated much beyond these temperatures.

A magnetic drive as just described is a synchronous device. That is, there is no slip between the inner and outer magnetic hubs. If the torque required by the pump exceeds the torque capability of the magnetic drive, the hubs will “disengage” driving, the pump will stop and, without instrumentation, the drive hub will continue to be rotated by the pump driver. Overheating and possible coupling damage can result if the decoupling is not detected and the driver shut down. Note that with the pumps stopped, as the driver is de-energized and slows, the magnetic coupling will re-engage at a low speed and cause the driver to stop more abruptly. This is characteristic and should not be cause for alarm.

Magnetic drive pumps are not suited to handling liquids with contaminant or hard material. The relatively close can-to-inner hub running clearance and the relatively thin can wall could result in a can failure if contaminant scores the can inside diameter. Consideration should be given to detection of leakage due to containment shell damage, especially if the pumped liquid is dangerous. Various arrangements are possible including optical switch, float switch, double wall containment can with space between inner and outer walls instrumented for leak detection, etc.

Figure 8: Magnetic drive external gear metering pump (Courtesy Micropump, Inc.)

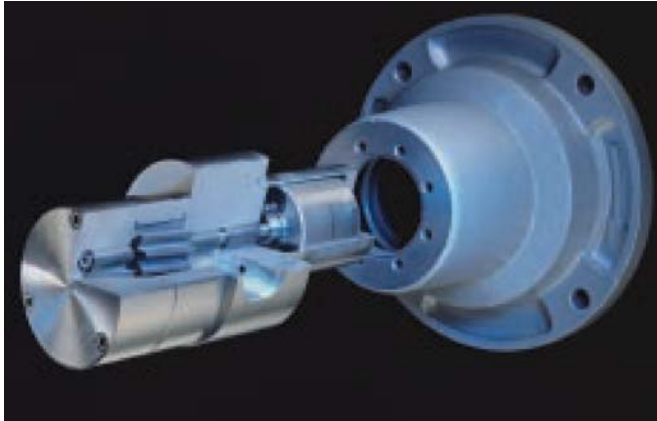

Gear Pumps

Figure 8 is a magnetic drive external gear pump. This particular design is for precision metering of very small flow rates between 0.0016 to 5 GPM (0.00036 to 1.14 m³/h). Variable speed drive would be a common arrangement for these pumps. Pumped liquid is trapped in the space between each gear tooth and the casing walls. This trapped volume is rotated to the discharge side of the pump where it is forced to exit by the meshing of the gear set. Each tooth space that is not open to the inlet or discharge chambers effectively acts like a stage causing a gradual pressure rise. Internal gear pumps have a bearing on both ends of the shaft to support loading due to hydraulic pressure acting on the gears from discharge towards inlet. Figure 9 is an internal gear type pump using magnetic drive. It includes a built-in discharge pressure relief valve. Note the temperature probe mounted to the outer frame. It is in contact with the containment shell and can

Figure 9: Magnetic drive internal gear pump with temperature probe (Courtesy Viking Pump)

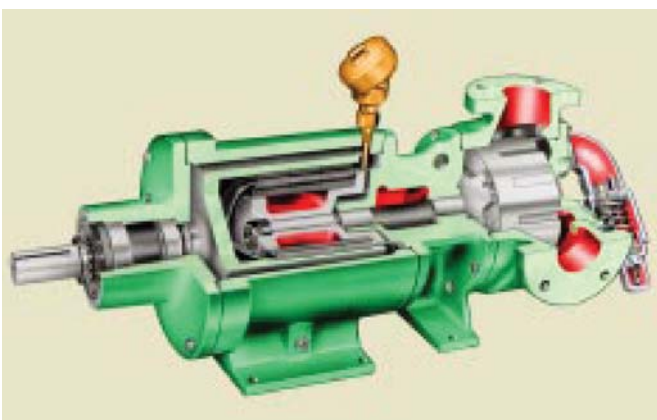
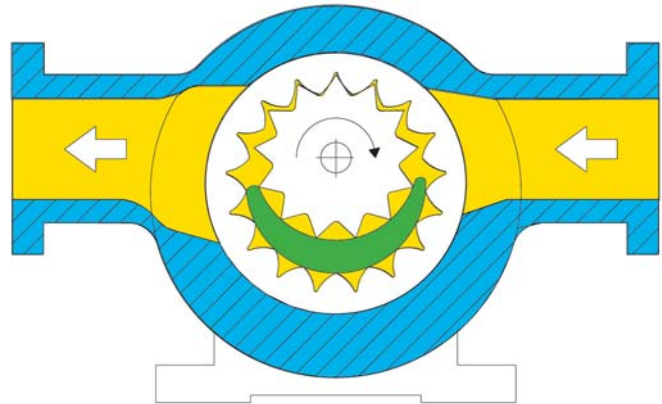
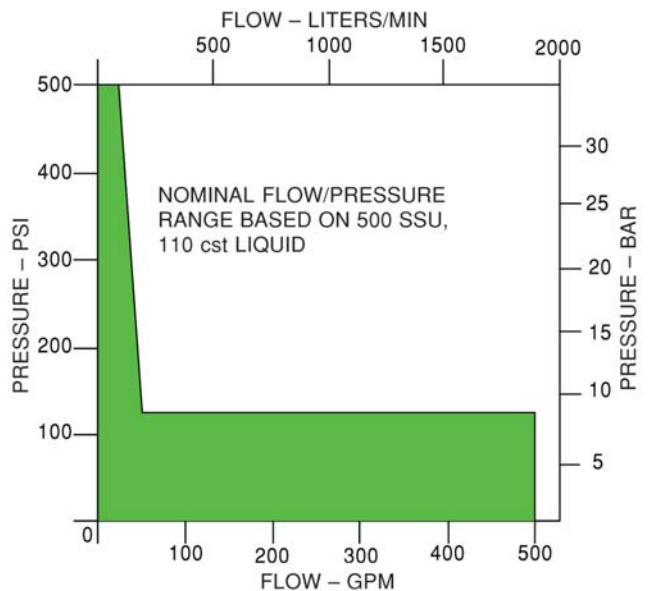

Figure 10: Positive displacement internal gear pump



detect excessive temperature and be used to alarm or shut down the drive. This style pump is available with wetted materials of cast iron, steel, stainless steel, composite and Hastelloy. Internal gear pumps, figure 10, trap pumped liquid between the gear teeth and an internal fixed crescent. Again, this trapped volume is rotated to the discharge side of the pump where it is forced to exit by the reengagement of the gear mesh. Like external gear pumps, there are normally two bearings, one on either side of the gear set to support radial loads due to pressure acting on the gears from discharge towards the pump inlet area. Flow and pressure capabilities are illustrated in figure 11. Magnetic drives for gear pumps are available for torque up to about 450 lbf-ft (610 N-m).

Figure 11: Magnetic drive internal gear pump pressure/flow range (Courtesy Viking Pump)



Flow/ressure range of internal gear magnetic drive pumps

Larger gear pumps need to run relatively slowly to keep filling velocities reasonable for good inlet pressure capability. They thus require larger magnetic drives for the same power range vs centrifugal pumps for example. Small displacement gear pumps running at four or six pole motor speeds make better use of magnetic couplings from a power (and coupling cost) point of view (power = torque X speed).

Vane Pumps

Vane pumps are available in magnetic drive arrangements. Like gear pumps, flow is radial and larger displacement pumps must run more slowly to provide good inlet pressure capabilities. A rotor containing vanes in slots rotates on a center offset from the larger diameter case bore center. Vanes may be spring loaded outward or may rely upon centrifugal force to keep them against the case bore. Liquid pumped is trapped between adjacent vanes, figure 12, and the inner pump

Figure 12: Positive displacement rotary vane pump

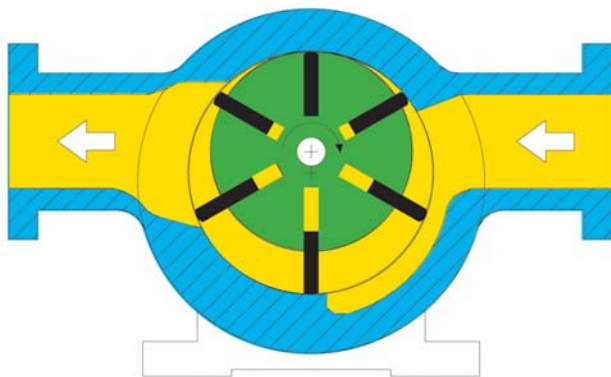

casing. It is expelled from the pump by the succeeding trapped volumes. Like internal and external gear pumps, vane pumps will have a bearing on either side of the rotor to support the shaft against hydraulically induced loading from discharge towards inlet. Vane pumps are available in flow rates of 4 to 330 GPM (0.9 to 75 m³/h) and suitable for pressures in the 100 to 125 psi (6.9 to 8.6 BAR) range. Circumferential casing or liner wear is somewhat compensated by the ability of the vanes to extend further radially as either the casing or vane wears. Some units are manufactured with a replaceable liner against which the vanes slide. These rotary vane pumps are available in ductile iron or 316 stainless steel construction. Since the number of vanes is small, there is little ability to stage the pressure

rise and so vane pumps are generally suited to low pressure applications. Balanced vane pumps are produced for hydraulic fluid power applications. While such designs are not available in sealless configurations, they are capable of several thousand psi operation on good quality hydraulic fluid.

Screw Pumps

Three screw pumps have also been successfully adapted to magnetic drive technology. Figure 13 illustrates typical construction. Flow in a screw pump is axial rather than radial as in a gear pump. Pumped

Figure 13: Magnetic drive three screw pump

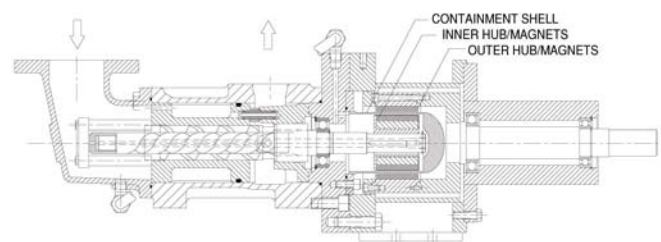

liquid is trapped in the space between the screw mesh and the casing or liner. As the screw set is rotated, the trapped volume is pushed towards the discharge port by the center screw. The two outside screws acts as seals between each otherwise separated volumes of liquid; they do no pumping. The volumes of liquid are expelled by the next trapped volumes behind it. In practice, one volume is opening while another is closing so the effective discharge area is constant and pressure pulsation and noise are minimal. As in gear pumps, each successive volume acts as a pressure stage. Pumps have been manufactured with twelve or more pressure stages for high pressure operation. Axial loads due to hydraulic pressure are normally balanced by the use of a balancing piston at the discharge end of the center screw and by bringing discharge pressure into a cavity at the inlet end of the two outside rotors. Radial loads are self-canceling due to the radial symmetry of the meshed screw set. Carbon fiber wound composite containment shells are available for the magnetic drive screw pump designs. The composite can virtually eliminates eddy current losses in the can yet provides good corrosion resistance on aggressive liquids. Cooling is provided to the driven internal coupling hub by allowing a small amount of pump discharge flow to circulate through the can and return to pump inlet via a drilled passage in the

shaft. Figure 14 shows the pressure/flow capability of three screw pumps. Their magnetic couplings have been supplied to 300 lbf-ft (405 N-m). Because three screw pumps typically operate at two or four pole electric motor speeds, the 300 lbf-ft (405 N-m) coupling is capable of handling power requirements up to 200 HP (150 KW) at 3500 rpm or 100 HP (75 KW) at 1750 rpm.

Figure 14: Magnetic drive three-screw pump pressure/flow range

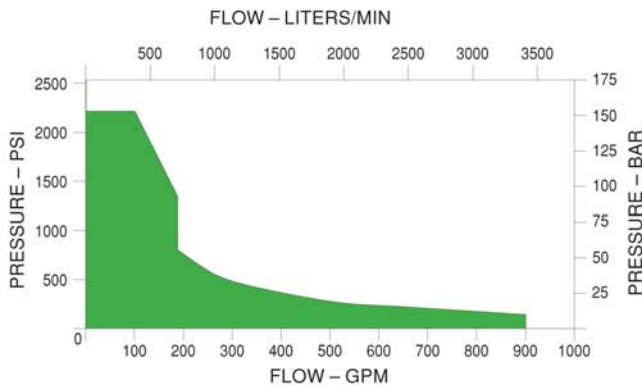

Flow/ressure range of three-screw magnetic drive pumps

Magnetic Drive Service Precautions

The larger torque magnetic drive couplings need to be handled with great care during disassembly/repair/reassembly. The attracting and repulsing forces can be very high and can easily result in injury or damage if both coupling hubs are not kept constrained at all times. Follow the pump manufacturer’s instructions with extra care to avoid problems. Plan the work area before beginning disassembly. A wooden table or thick sheet of plywood over a metal table should be used. Know where hand tools will be placed after each use. Know where each pump component will be placed upon removal so that the magnets will not “leap” together or attract a hand tool and cause damage. Jacking magnetic coupling hubs apart or together is a common method of keeping them under control. Do not place hands or fingers between components parts while the hubs are near enough to each other to still attract or repulse. Do not allow the magnetic hubs to be near electronic equipment, instrumentation, wrist watches, credit or magnetic identification cards, computers, floppy diskettes, etc. The intense magnetic field can damage or destroy such devices. People with pace makers or other implanted metallic, electric or electronic devices should not be allowed near magnetic hubs unless they are contained within an assembled pump or adequately boxed to keep their fields at a reasonable distance from container handling. The

hubs should be immediately wrapped in clean cloth after removal to prevent magnetic debris such as machining chips, filings, etc. from attaching to the magnets. If allowed within the coupling, such debris can begin scoring the containment can wall and weaken or fail the can. Magnetic components (magnets, hubs, complete pumps) are potentially hazardous to aircraft. Check with your carrier for packaging requirements. Parts or units packaged for air shipment may be required to be within a specific gauss measurement limit.

Operation – Canned Motor/Pumps

Rotary pumps can be canned adopting concepts similar to centrifugal pumps. The hydraulic elevator pump in figure 3 is almost a canned motor/pump. By supplying an inlet cover for pipe connection in lieu of the inlet strainer shown and completely closing the electric motor, the result is a canned motor/pump. Figure 15 shows the construction of a three-screw canned motor pump. It is of the wet stator design

Figure 15: Canned sealless three-screw pump

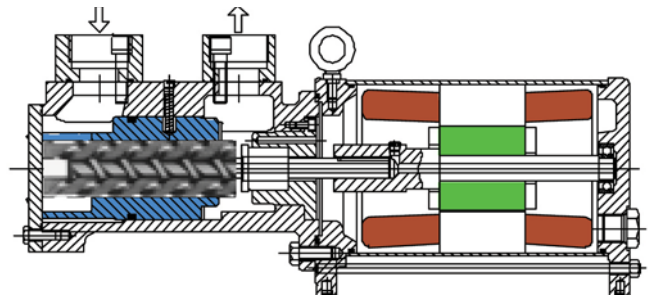

meaning that the liquid pump, which also circulates within the motor for cooling, must be compatible with the winding insulation as well as the rotor laminations. This compatibility issue limits the wet stator design to applications on relatively non-aggressive liquids. By placing non-magnetic, corrosion resistant containment barriers around both the rotor and stator, a dry stator design is created with broader application range for more aggressive liquids. Current wet stator designs reach 6 HP (4.5 KW) at 3500 rpm and can deliver flows to 100 GPM (23 m³/h) or handle differential pressures to 1000 PSI (69 BAR). Canned rotary motor/pumps are currently being designed in the 100 HP (75 KW) range. Full load speeds are somewhat slower for canned motor/ pumps due to the drag of the motor rotor in the liquid pumped i.e. 3450 RPM and 1725 RPM nominal for small 60 HZ, two and four pole motors respectively. Like their magnetic drive counterparts, canned motor/pumps are not well suited to handling liquids containing solids, contaminants or abrasive particles.

Sealless pump technology has come a long way but still needs improvement especially in the area of price/cost. Magnetic drive pumps are relatively expensive. Canned motor technology promises some improvement in sealless pump costs as more sizes and designs are developed. The future of pump users will see more and more regulation on the amounts and types pump emissions permitted. The use of sealless technology as well as gas sealing technology will be driven but such regulation. Given the frequency and cost of conventional seal replacement, sealless pumping may very well compete with the life cycle costs of conventional sealed pumps. Including fines for emission violations, there may be no contest at all for the pumping of highly regulated liquids.

The following pump manufacturers contributed information and illustrations: Micropump, Inc., Tuthill Corp., and Viking Pump, Inc.

This is the unedited text of a technical presentation made by Colfax Corporation's Jim Brennan at Pump Users Expo '98, Cincinnati, OH, USA, 29 October 1998.

About Colfax Corporation

Colfax Corporation is a global leader in critical fluid-handling solutions, including the manufacture of positive displacement industrial pumps and valves used in global oil & gas, power generation, marine, Naval and a variety of other industrial applications. Key product brands include Allweiler, Fairmount Automation, Houttuin, Imo, LSC, Portland Valve, Tushaco, Warren and Zenith. Colfax is traded on the NYSE under the ticker "CFX." Additional information about Colfax's products, businesses and practices is available at www.colfaxcorp.com.

About Colfax Oil & Gas Solutions

Colfax has served virtually every oil company throughout the world over the past 90 years, bringing particular critical expertise to crude oil transport in production facility, pipeline, tank farm and refinery applications and surrounding customers with design, engineering, manufacture, installation, testing and technical support services. The Colfax portfolio of pumping technologies delivers not only unsurpassed reliability, but operational and energy efficiencies, environmental responsibility and cost savings over the life cycle of the pump.

Colfax Corporation
8730 Stony Point Parkway
Suite 150
Richmond, VA 23235 USA
T: 804.327.5689
F: 804.560.4076

www.colfaxcorp.com

Colfax Americas
1710 Airport Road
Monroe, NC 28110 USA
T: 704.289.6511
F: 704.289.9273

Colfax Asia Pacific
Unit 7, 31st Floor
Laws Commercial Plaza
788 Cheung Sha Wan Road
Lai Chi Kok, Kowloon
Hong Kong, China
T: +852.2136.8023
F: +852.2136.8026

Colfax Europe,
Middle East, Africa
Allweilerstr. 1
78301 Radolfzell
Germany
T: +49 (7732) 86.0
F: +49 (7732) 86.436